

INSTALLER CODE
(default code 54321)

5 4 3 2 1

If the code has been entered correctly,
the LEDs 1 to 5 blink 3 times and
the buzzer sends out 3 beeps.



CONTROL PANEL PARAMETERS

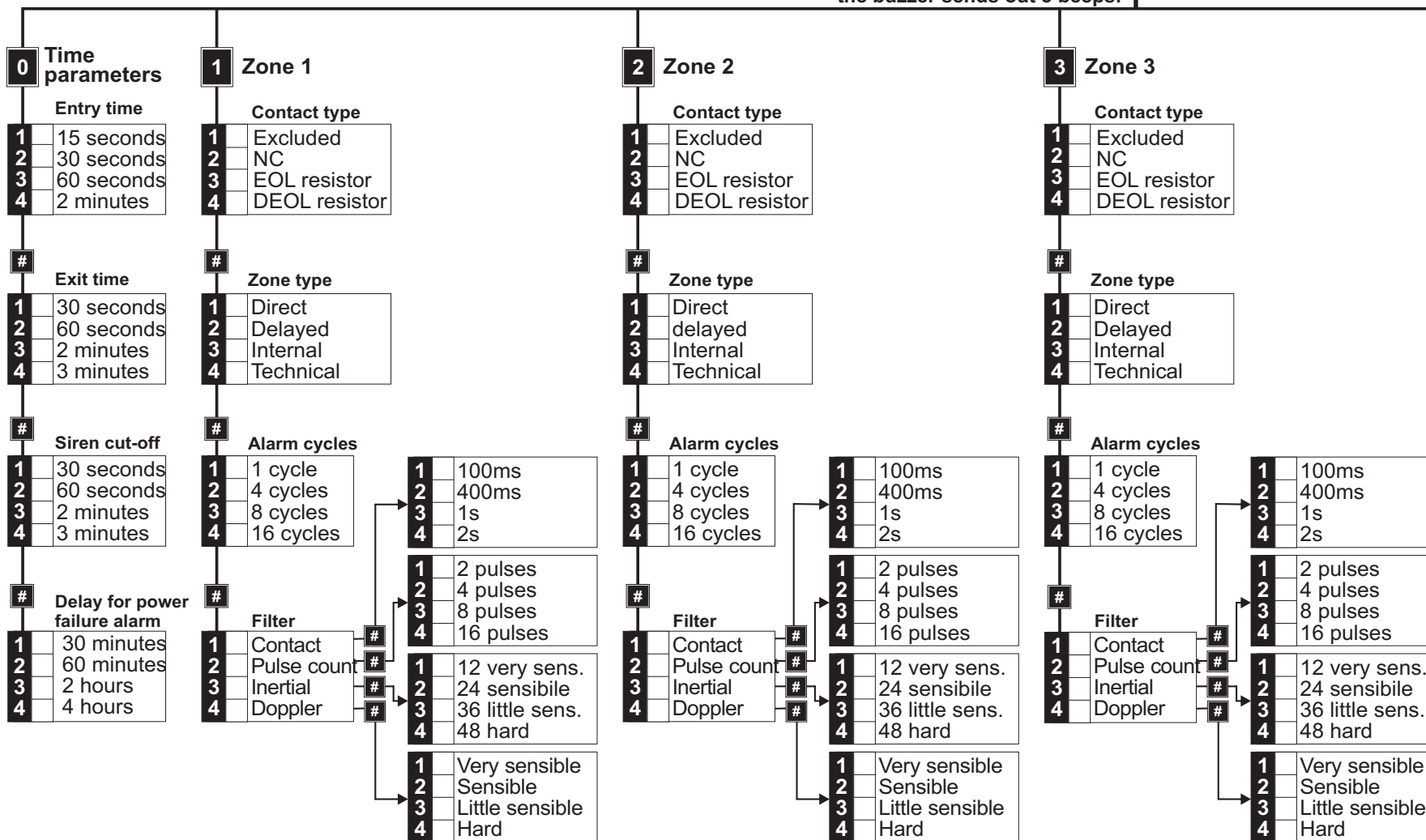



CONTROL PANEL PARAMETERS

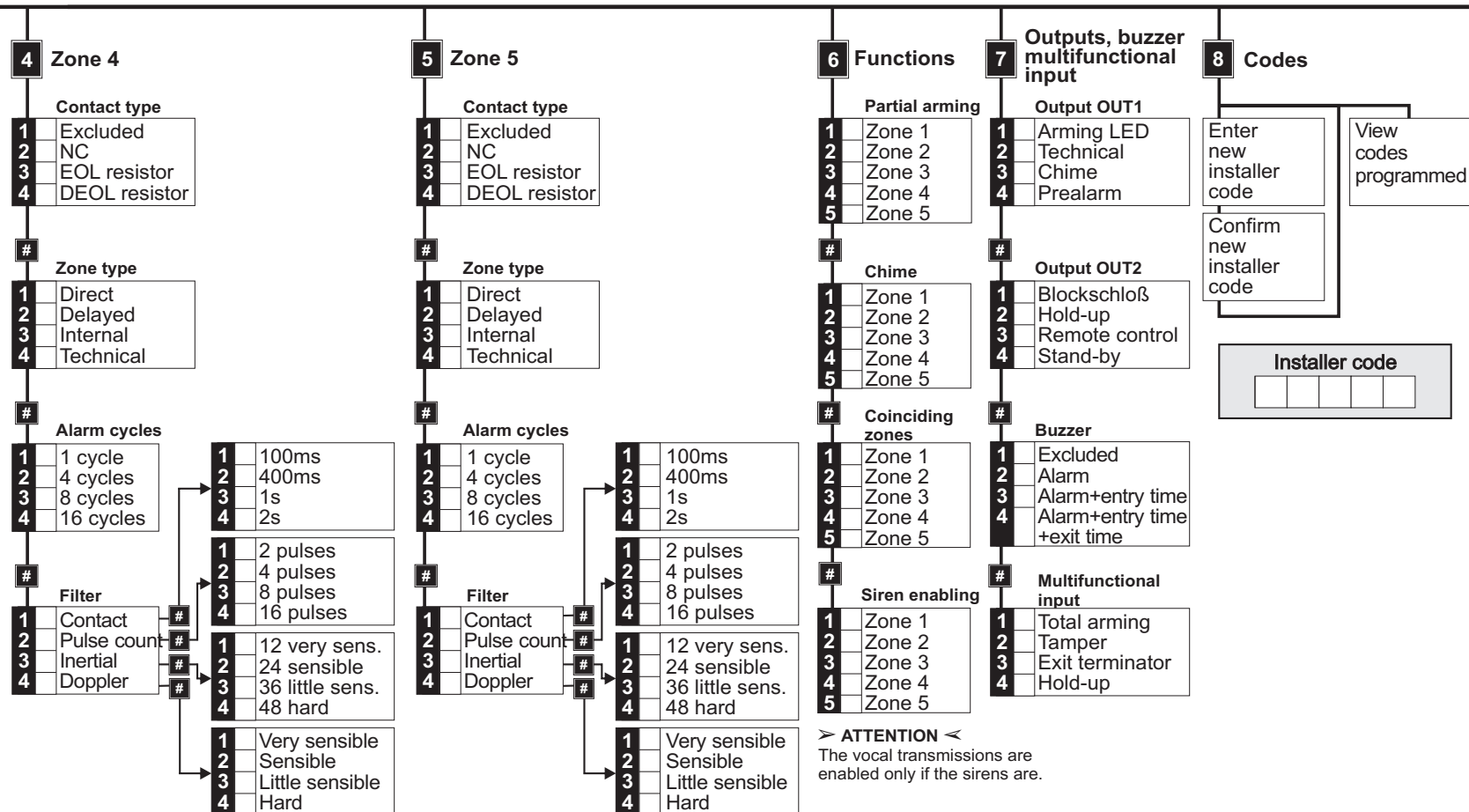

> **ATTENTION** <
The vocal transmissions are enabled only if the sirens are.



PARAMETERS OF THE TELEPHONE COMMUNICATOR

9 1 Digital channel

Principal telephone N°
(max. 16 figures)

--	--	--	--	--	--	--	--	--	--	--	--	--	--	--	--

#

Spare telephone N°
(max. 16 figures)

--	--	--	--	--	--	--	--	--	--	--	--	--	--	--	--

#

Transmission format
(00 to 99)

--	--

ID code of the control panel
(max. 4 digits)

--	--	--	--

9 2 Vocal channel

1° telephone number
(max. 16 figures)

--	--	--	--	--	--	--	--	--	--	--	--	--	--	--	--

#

2° telephone number
(max. 16 figures)

--	--	--	--	--	--	--	--	--	--	--	--	--	--	--	--

#

3° telephone number
(max. 16 figures)

--	--	--	--	--	--	--	--	--	--	--	--	--	--	--	--

9 3 TECNOALARM channel

Call back number
(max. 16 figures)

--	--	--	--	--	--	--	--	--	--	--	--	--	--	--	--

#

Si No Functions

1		Zone alarms
2		arming
3		system status
4		call for 80% event
		buffer capacity
		technical alarms

#

ID code of the control panel
(4 digits)

--	--	--	--

9 4 Other parameters

Si No General control

1		DTMF	<input type="checkbox"/>	Pulse	<input type="checkbox"/>
2		Dial hum check		Ring-back check	
3		Confirmation on answering			
4					

#

Number of rings
(3 to 7)
0 = answering mode disabled

--

#

Internal switch board number
(0 to 99)
* to cancel

--	--

9 5 Report codes for zone alarm

Beginning of alarm

Zone 1	<input type="checkbox"/>
Zone 2	<input type="checkbox"/>
Zone 3	<input type="checkbox"/>
Zone 4	<input type="checkbox"/>
Zone 5	<input type="checkbox"/>

End of alarm

Zone 1	<input type="checkbox"/>
Zone 2	<input type="checkbox"/>
Zone 3	<input type="checkbox"/>
Zone 4	<input type="checkbox"/>
Zone 5	<input type="checkbox"/>

Zone exclusion

Zone 1	<input type="checkbox"/>
Zone 2	<input type="checkbox"/>
Zone 3	<input type="checkbox"/>
Zone 4	<input type="checkbox"/>
Zone 5	<input type="checkbox"/>

9 6 Report codes for technical alarms

1° part

Beginning of zone tamper	<input type="checkbox"/>
End of zone tamper	<input type="checkbox"/>
False code	<input type="checkbox"/>
Reset timer	<input type="checkbox"/>
Tamper	<input type="checkbox"/>

2° part

Beginning of low battery	<input type="checkbox"/>
End of low battery	<input type="checkbox"/>
Power failure	<input type="checkbox"/>
Return of mains	<input type="checkbox"/>
Test call	<input type="checkbox"/>

9 7 Report codes for arming

Arming

Master code	<input type="checkbox"/>
User code 1	<input type="checkbox"/>
User code 2	<input type="checkbox"/>
User code 3 or quick arming	<input type="checkbox"/>
Remote code	<input type="checkbox"/>

Disarming

Master code	<input type="checkbox"/>
User code 1	<input type="checkbox"/>
User code 2	<input type="checkbox"/>
User code 3 or quick arming	<input type="checkbox"/>
Remote code	<input type="checkbox"/>

Other

Partial arming	<input type="checkbox"/>
Hold-up	<input type="checkbox"/>
Arming by key	<input type="checkbox"/>
Disarming by key	<input type="checkbox"/>
Exclusion of zones	<input type="checkbox"/>

The report codes are 2-digits codes (00 to FF).
Once entered the code, the control panel automatically passes to the next code. To skip a code, press #.

230V AC

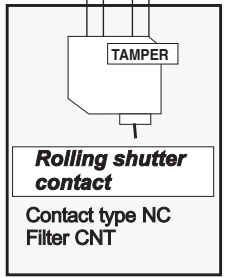
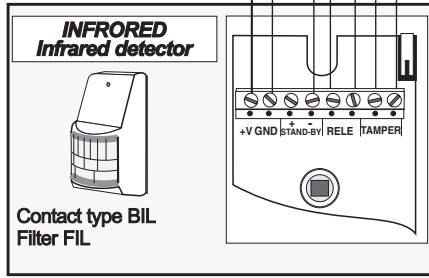
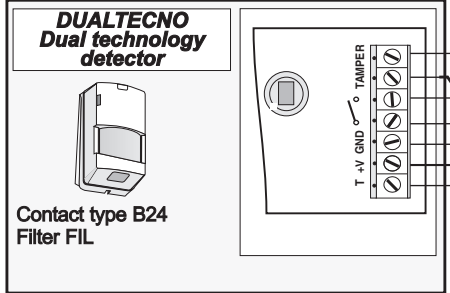
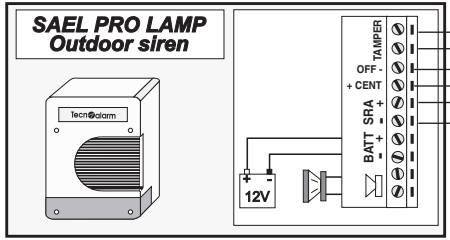
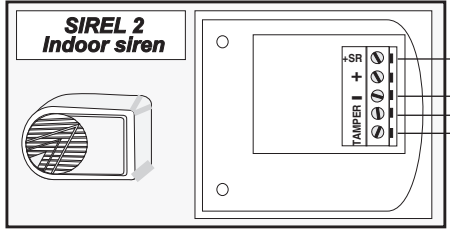
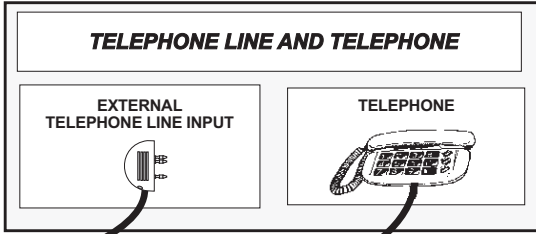
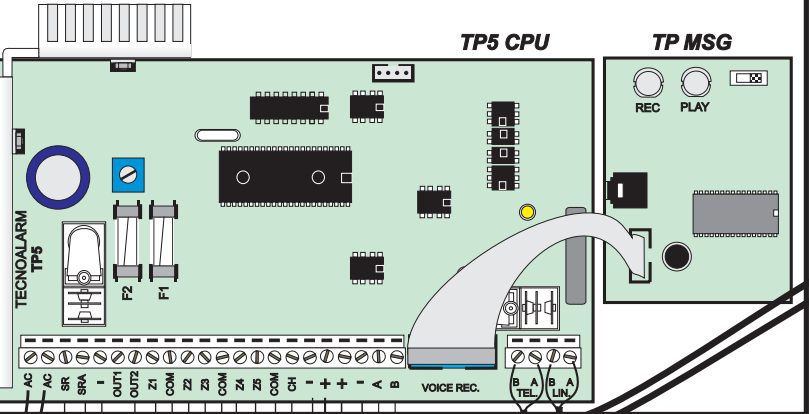
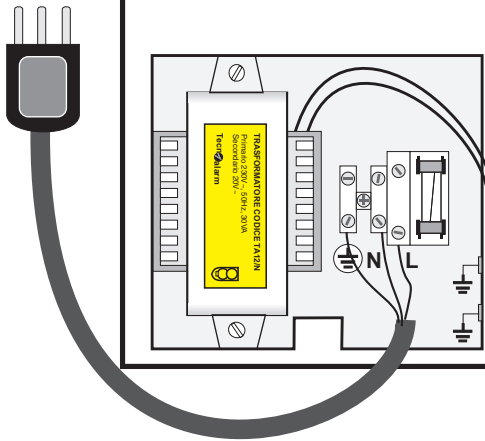

ATTENTION
 In this example, the output OUT2 has to be programmed as stand-by output. The input Z5, if used as tamper input, has to be programmed as end-of-line resistor contact. So have the unused zones. Bridge the zone terminal (Zx) and the corresponding common terminal (COM) with the help of the resistance included (see the connection of zone 4).

ATTENTION
 If the multifunction input CH is not used, bridge the terminals CH and COM with the help of the resistance included.

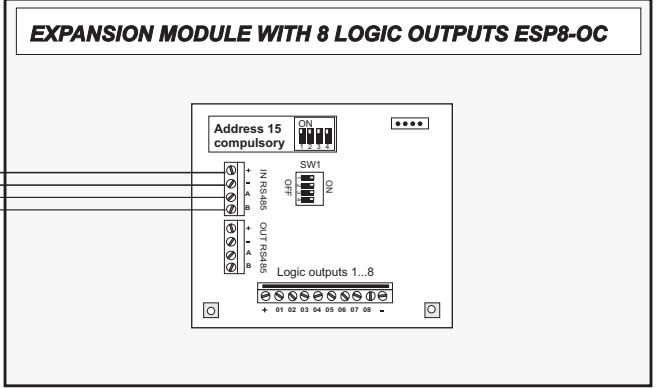
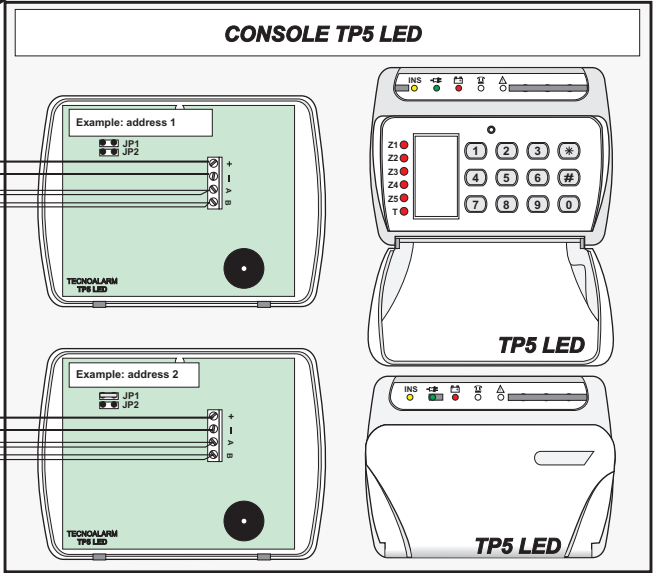

TP5 GLOBAL CONNECTION PLAN